

Operator's manual



TruTool S 350 (1A1)

english

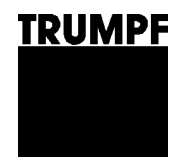

Table of contents

1.	Safety	3
2.	Description	5
2.1	Correct use	6
2.2	Technical data TruTool S 350	7
3.	Tool assembly	8
3.1	Changing the stroke rate	8
3.2	Workstation (optional).....	9
3.3	Selecting the blade	11
3.4	Setting the cutting clearance	13
	Cutting clearance.....	14
3.5	Setting the height of the moving cutter blade	15
4.	Operation	17
	Working with the TruTool S 350	18
5.	Maintenance	19
5.1	Changing the blade.....	21
	Turning the moving cutter blade over or replacing it	21
	Turning the fixed cutter blade over or replacing it	21
5.2	Replacing carbon brushes	21
6.	Wearing parts	22
7.	Original accessories.....	23
8.	Options	23

Warranty

Replacement parts list

Addresses

1. Safety

- USA/CAN** ➤ Read the Operator's Manual and the general safety rules (Material number 1239438, red document) in their entirety before starting up the machine. Follow precisely the directions contained therein.

- Rest of the world** ➤ Read the Operator's Manual and the safety instructions (Material number 125699, red document) in their entirety before starting up the machine. Follow precisely the directions contained therein.
- The safety regulations according to DIN VDE, CEE, AFNOR and other regulations which are valid in individual countries should be adhered to.



Danger

Lethal danger due to electric shock!

- Remove the plug from the plug socket before undertaking any maintenance work on the machine.
- Check the plug, the cable and the machine for damage each time before the appliance is used.
- Keep the machine dry and do not operate in damp rooms.
- When using the electric tool outside, connect the fault current (FI) protective switch with a maximum breaking current of 30 mA.
-



Warning

Danger of injury possible due to incorrect handling!

- When working with the machine, wear safety glasses, hearing protection, protective gloves and work shoes.
- Do not plug in the plug unless the machine has been switched off. Pull out the mains plug after use.
-



Warning

Risk of injury to the hands!

- Do not place your hand into the processing line.
- Use both hands to hold the machine.
-



Caution

Damage to property possible due to incorrect handling!

The machine will be damaged or destroyed.

- Do not use the power cord to carry the machine.
 - Always lead the cable away from the back of the machine and do not pull it across sharp edges.
 - Arrange for start-ups and checks on manual electric tools to be carried out by a trained specialist. Use only original accessories provided by TRUMPF.
-



Warning

Risk of injury from chip!

- Use chip deflector.
-

2. Description

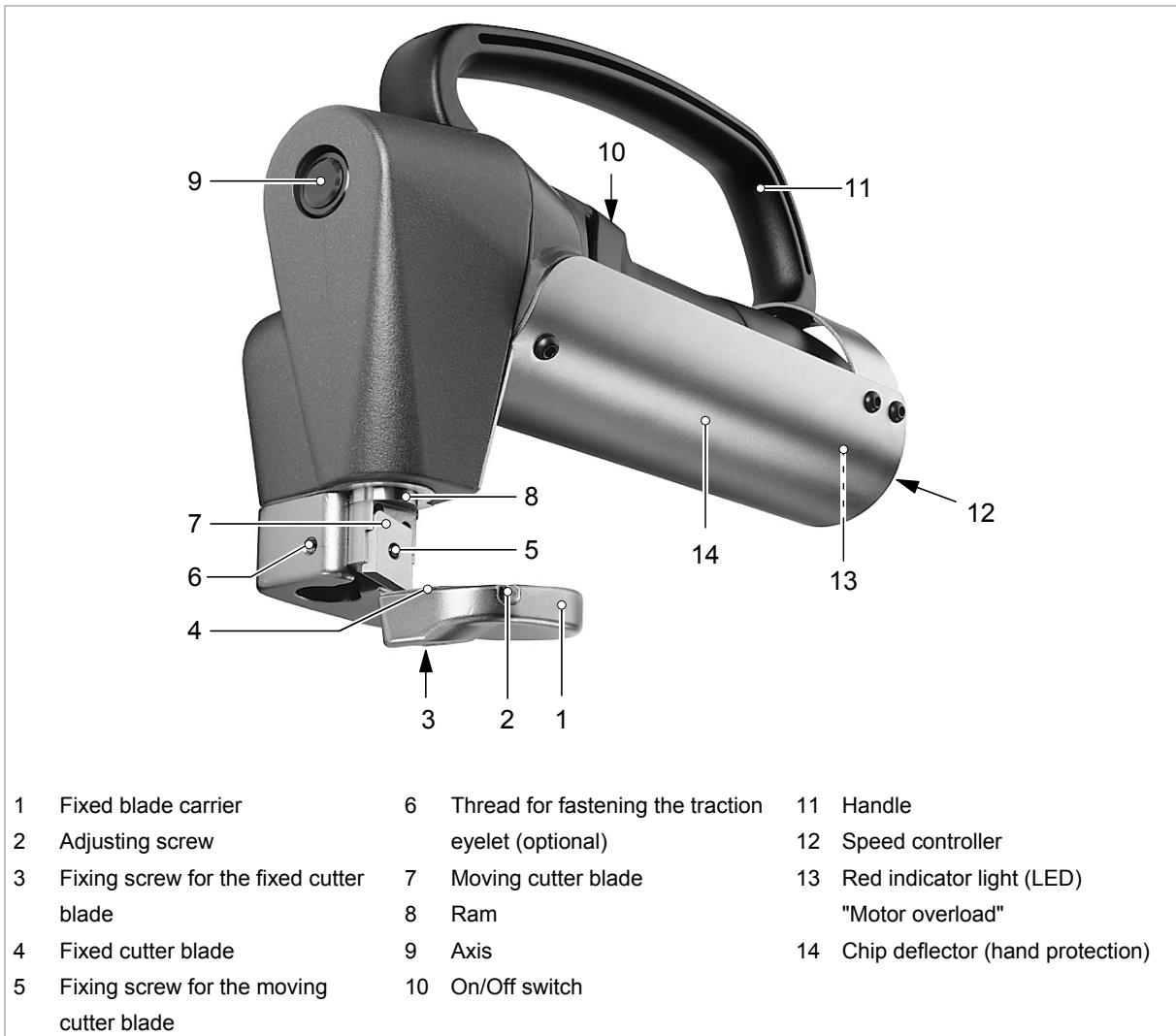

TruTool S 350

Fig. 28474

2.1 Correct use



Warning

Risk of injury!

- Use the machine only for the tasks and materials described in "Correct use".
-

The TRUMPF TruTool S 350 portable shears are an electric hand tool used for the following applications:

- Chip-free slitting and edge-planing of plate-shaped workpieces made of steel, aluminium, non-ferrous heavy metals and plastic.
- Production of straight or curved exterior and interior cutouts.
- Slitting along scribed lines.
- Slitting of coils.

2.2 Technical data TruTool S 350

	Rest of the world			USA
	Values	Values	Values	Values
Voltage	230 V	120 V	110 V	120 V
Frequency	50/60 Hz	50/60 Hz	50/60 Hz	50/60 Hz
• Steel 400 N/mm ²	3.5 mm (Coil 3.0 mm)	3.5 mm (Coil 3.0 mm)	3.5 mm (Coil 3.0 mm)	0.138 in 0.12 in
• Steel 600 N/mm ²	3.0 mm (Coil 2.5 mm)	3.0 mm (Coil 2.5 mm)	3.0 mm (Coil 2.5 mm)	0.12 in 0.1 in
• Steel 800 N/mm ²	2.0 mm (Coil 1.5 mm)	2.0 mm (Coil 1.5 mm)	2.0 mm (Coil 1.5 mm)	0.079 in 0.06 in
• Aluminium 250 N/mm ²	4.0 mm	4.0 mm	4.0 mm	0.16 in
Working speed	4-6 m/min	4-6 m/min	4-6 m/min	13-20 ft./min
Nominal power consumption	1400 W	1200 W	1140 W	1200 W
Stroke rate with idle run	1640/min	1480/min	1480/min	1480/min
Weight	5.6 kg	5.6 kg	5.6 kg	12.4 lbs
Smallest radius with right/left cutouts	16 mm	16 mm	16 mm	0.623 in
Starting hole diameter	50 mm	50 mm	50 mm	1.97 in
Protective insulation	Class II	Class II	Class II	Class II

Technical data

Table 1

Noise and vibration	Measured values in accordance with EN 50144
A-weighted sound level	Typically 86 dB(A)
A-weighted acoustic power level	Typically 94 dB(A)
Hand-arm vibration	Typically less than or equal to 2.7 m/s ²

Measured values for noise and vibration

Table 2

Note

The measured values specified above may be exceeded while working.

3. Tool assembly

3.1 Changing the stroke rate

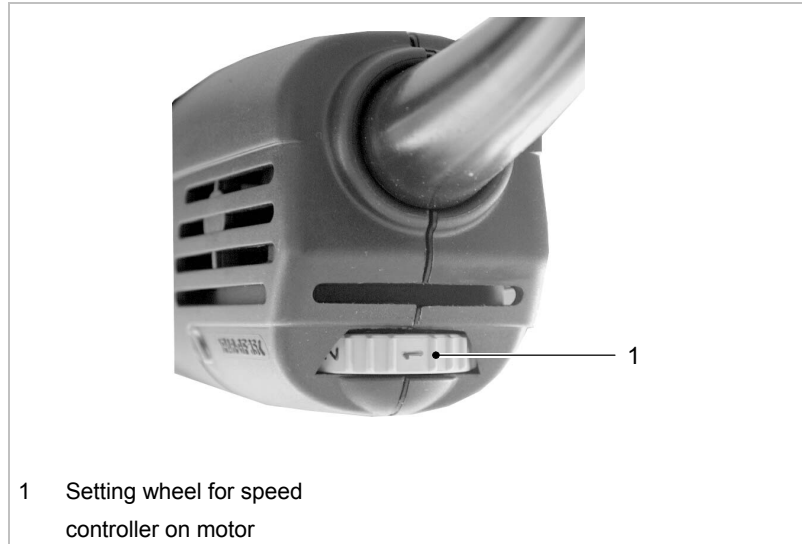

Speed controller

Fig. 27948

Reducing the stroke rate

- Rotate the setting wheel for the speed controller counter-clockwise.

A reduced number of strokes improves the quality of the work

- For precise machining along scribed lines.
- For machining radiuses.
- For machining steel with a tensile strength $> 400 \text{ N/mm}^2$ (improved service life).

3.2 Workstation (optional)



Caution

Damage to property can result from incorrect operation!

- Do not slide the workpiece into the machine until the machine has been switched on and it has reached its full revolutions per minute.



Danger

Lethal danger due to electric shock!

- Pull the plug out of the socket when carrying out tool changes and before all maintenance work on the machine.

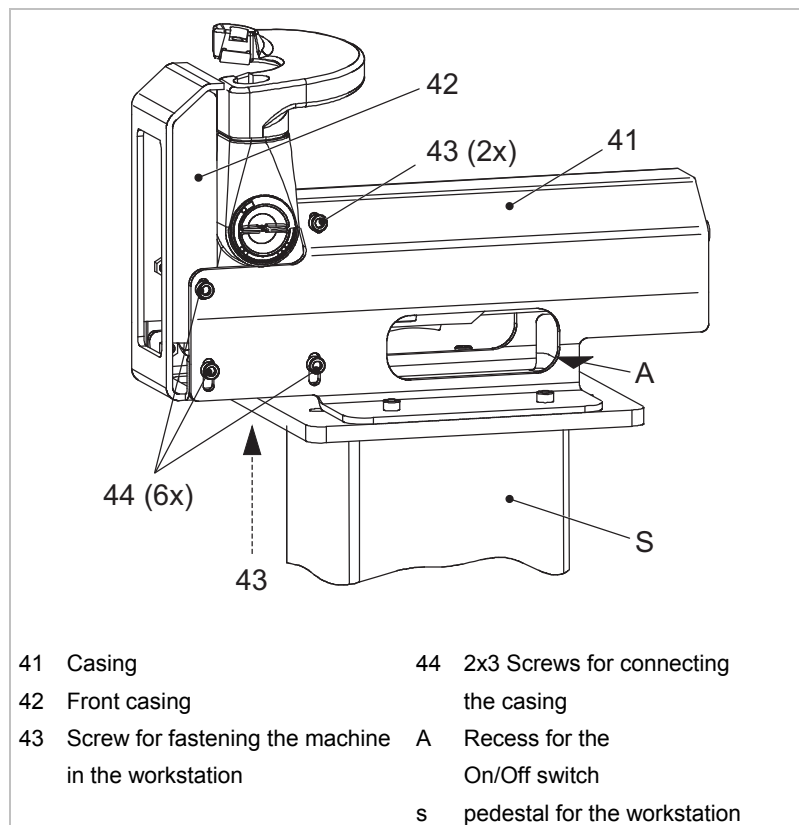

Workstation

Fig. 17461



Example: machining a workpiece

Fig. 17464

The workstation (Order No. 979371) in which the machine can be fastened is used for machining small workpieces. This workstation can be bolted down through mounting holes

- To a base plate (workbench) or
 - to a pedestal (Order No. 003677).
1. Screw on bracket and chip deflector.
 2. Place machine in the casing (41).
 3. Secure the setting device with the screws (43).
 4. Use the screws (43 and 44) to secure the machine tightly in the casing
 5. Fasten the workstation to a workbench or on top of the TRUMPF pedestal (Order No. 003677) with 4 screws.

3.3 Selecting the blade



Caution

Damage to property can result from incorrect blade selection!

The quality of the cut will be severely impaired and the individual tools will be overloaded.

- Use only appropriate tools.
-

The blade is notable for the following points:

- Moving cutter blade (upper blade) and fixed cutter blade (lower blade) are identical in shape and can be used interchangeably (above or below).
- All blades have two cutting edges.
- They are non-regrindable "2-way multi-edge or throw-away cutters".

Note

2 different blade types can be selected for the machining process, depending on the thickness or the tensile strength of the workpiece (see Table 3, Pg. 12).

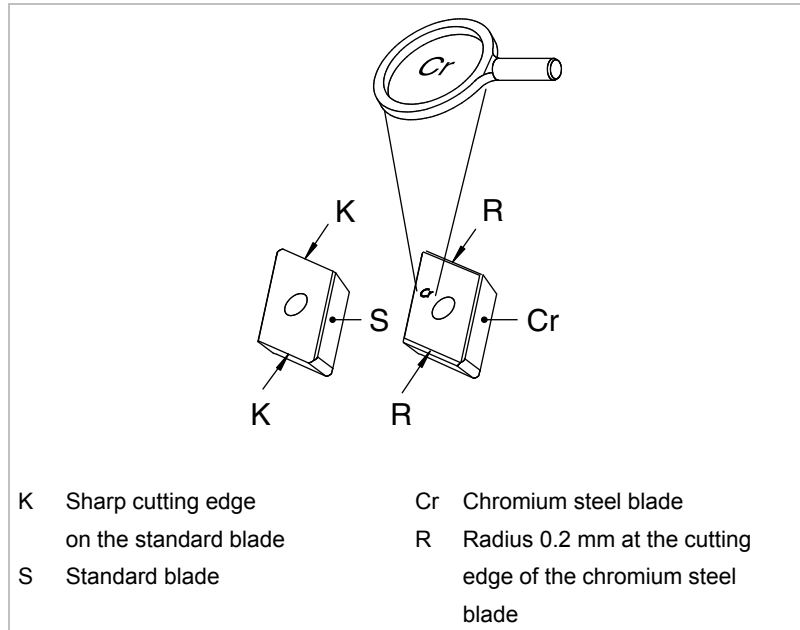

- K Sharp cutting edge on the standard blade
- S Standard blade
- Cr Chromium steel blade
- R Radius 0.2 mm at the cutting edge of the chromium steel blade

Blade with type identification

Fig. 14843

Note

Standard blades with a tensile strength of $\leq 400 \text{ N/mm}^2$ have no special identification marking. Chromium steel blades are marked with "Cr".

Note

For these reasons, it is highly recommended that only such tools be used as those which correspond to the specifications contained in this table.

Blade type	Sheet thickness ranges mm	Type of material and Tensile strength	Material No.
Standard	0.5-4.0	Aluminium 250 N/mm ²	140451
Standard	0.5-3.5 Coil 0.5-3.0	Mild steel 400 N/mm ²	140451
Standard	0.5-1.5 Coil 0.5-1.0	Stainless steel 600 N/mm ²	140451
Standard ¹	1.5-3.0 Coil 1.9-2.5	Stainless steel 600 N/mm ²	140451
Cr	1.5-3.0	Stainless steel 600 N/mm ²	140452
Cr	0.5-2.0 Coil 0.5-1.5	Stainless steel 800 N/mm ²	140452

Table 3

¹ Utilisation is possible with advanced wearing

3.4 Setting the cutting clearance



Danger

Lethal danger due to electric shock!

- Pull the plug out of the socket when carrying out tool changes and before all maintenance work on the machine.

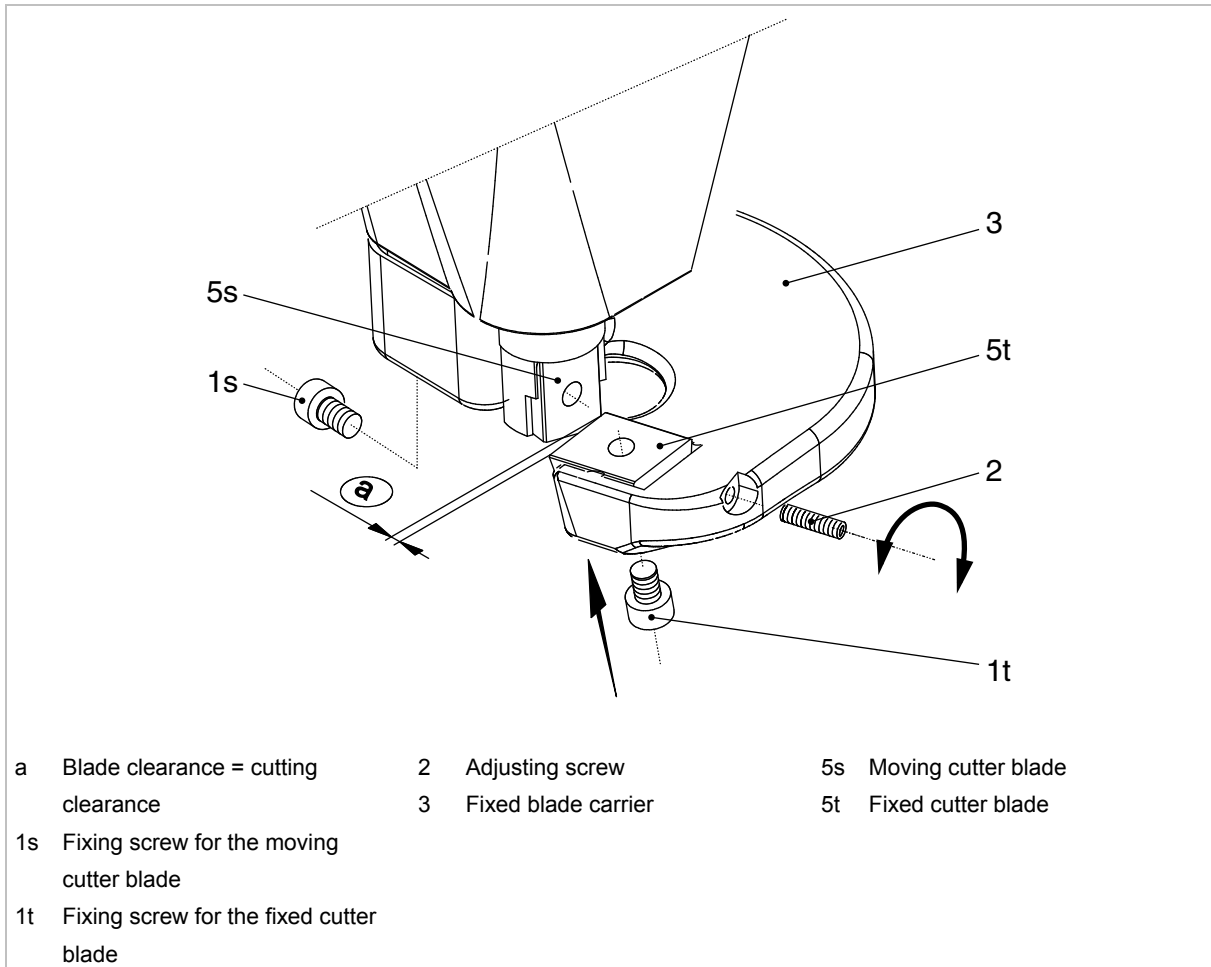

Fig. 14844

1. Push the On/Off switch several times until the moving cutter blade (5s) has reached the lower dead point.
2. Screw on the fixed cutter blade (5t) loosely with the fixing screw (1t).
3. Using the adjusting screw (2), set the fixed cutter blade (5t) to the desired cutting clearance (check with a feeler gauge).
4. Tighten the fixing screw (1t).
5. Tighten the adjusting screw (2) slightly.



Cutting clearance

The cutting clearance must amount to 0.2x of the sheet thickness to be cut.

Examples:

Sheet thickness "s" [mm]	Blade clearance = cutting clearance "a" [mm]
0.5	0.1
1.0	0.2
2.0	0.4
3.0	0.6
3.5	0.7

Table 4

3.5 Setting the height of the moving cutter blade

In order to ensure the realisation of optimum cutting behaviour for both the slitting of metal sheets and the cutting of curved lines, the clearance between the moving cutter blade and the fixed cutter blade (penetration depth into the sheet) must be adjusted in accordance with both the projected cutting task and the sheet thickness.

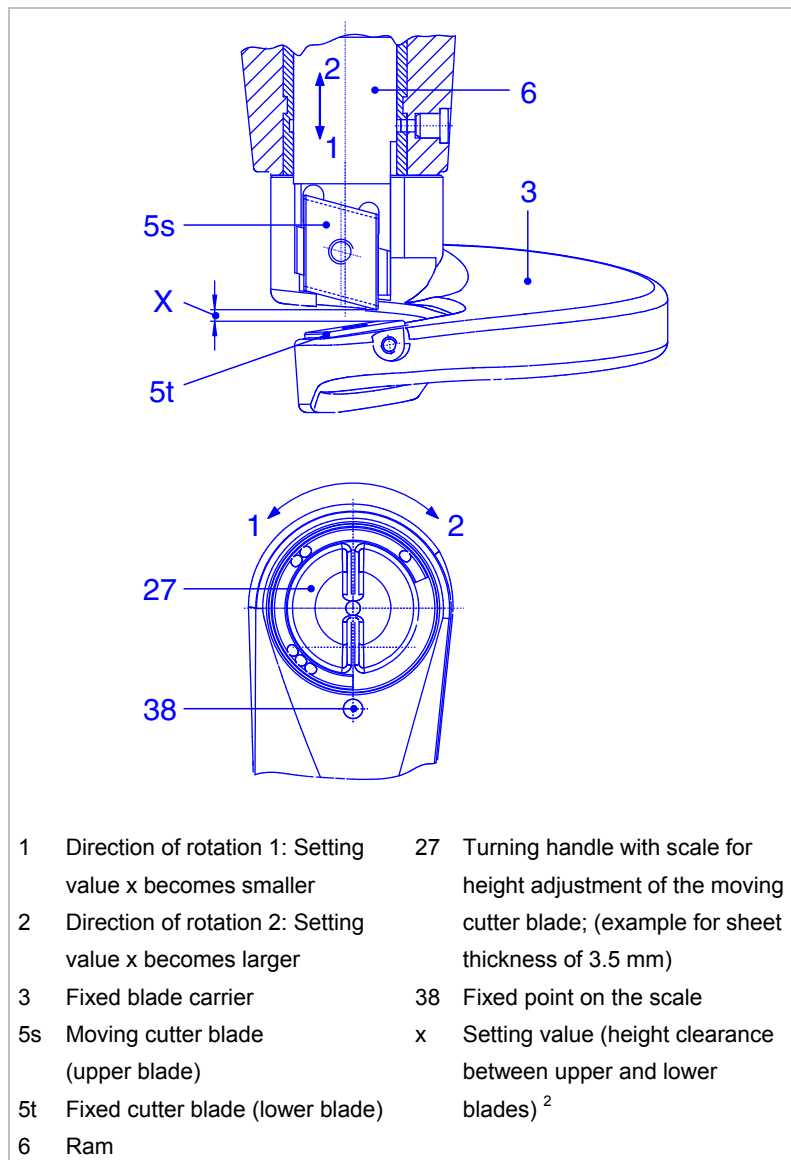

Height adjustment of the moving cutter blade

Fig. 14845

² The ram is located at the upper dead point.

**Changing the height
clearance between moving
cutter blade and fixed
cutter blade**

1. Push the turning handle when the machine is either running or switched off and rotate it.
2. The turning handle locks into place when it is released.
3. Marker points have been placed on the turning handle (27) which are to be positioned in accordance with sheet thickness and the particular application to be carried out.
4. Altering the clearance between the two blades allows optimisation of cutting behaviour to match particular applications.

Note³

- (+) intermediate stage in direction of rotation 2
 (-) intermediate stage in direction of rotation 1

Sheet thickness [mm]	Setting of the turning handle for the cutting of curves	Setting of the turning handle for the cutting of straight lines	Setting of the turning handle for the cutting of coils
3.5	3(+)	3(+)	-
3.0	3(+)	3	1
2.5	3	2(+)	1
2.0	2(+)	2	1
1.5	2	1(+)	1
1.0	1(+)	1	1
0.5	1	1(-)	1(-)

Table 5

³ The settings listed in the Table are recommended values.

4. Operation



Caution

Damage to property possible due to too-high network voltage!

Damage to the motor

- Check the power supply. The power supply voltage must correspond to the specifications on the machine type plate.
 - When using an extension cord which is longer than 5 m, take care to ensure that it has a line diameter of at least 2.5 mm².
-



Caution

Danger of injury possible due to incorrect handling!

- When working with the machine, always ensure that it is positioned securely.
 - Never touch the tool while the machine is running.
 - Always guide the machine away from the body while working
-

Electromagnetic interference

The appliance may switch off prematurely when affected by electromagnetic disruptions. The appliance will resume operation once the faults have been cleared.

Motor overload protection

If the motor temperature is too high, the motor will switch off. The red indicator light (LED) with the motor lights up.

- Allow the machine to run in idle until it has cooled down.

The machine can be operated again normally after it has cooled down.

Working with the TruTool S 350

Switching on the TruTool S 350

- Move the On/Off switch to the front.

Working with the TruTool S 350

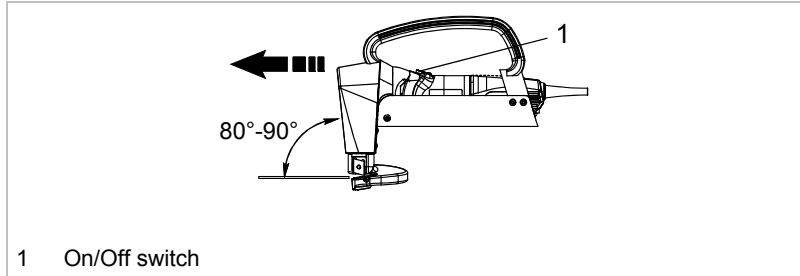

1 On/Off switch

Fig. 28475

1. Do not move the machine towards the workpiece until full speed has been reached.
2. Machine/process the material
 - Move the device forward at an angle of 80 to 90° to the sheet surface.

Requirements for the cutting of radiuses

- Do not tilt the machine.
- Proceed with a low feed rate.

Requirements for cutting near the margin

- Cut in upside-down position, meaning that the cutting table is facing upwards.

Switching off the TruTool S 350

- Move the On/Off switch to the rear.

5. Maintenance



Danger

Lethal danger possible due to electric shock!

- Pull the plug out of the socket when carrying out tool changes and before all maintenance work on the machine.
-



Caution

Damage to property possible due to blunt tools!

Overloading of the machine.

- Check the cutting edge of the cutting tool hourly for wear. Sharp blades provide good cutting performance and are easier on the machine. Replace blades promptly.
-



Caution

Risk of injury possible due to improper repairs!

The machine does not function properly.

- Repairs should be carried out only by a trained specialist.
-

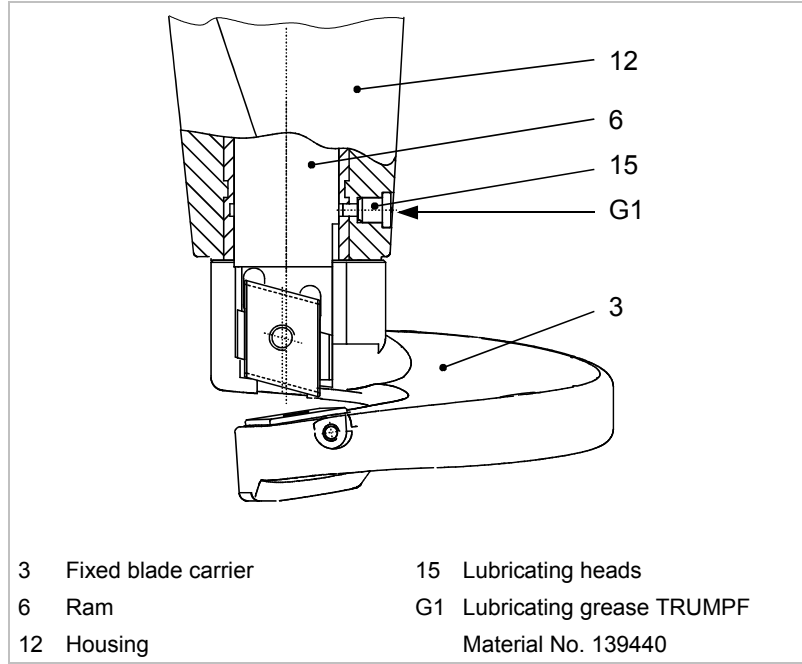

Grease nipple, ram guide

Fig. 28476

Maintenance point	Procedure and time interval	Recommended lubricants	Order No. Lubrication agents
Ram guide	Every 20 operating hours.	"G1" lubricating grease	139440
Gearbox and gear head	After 300 operating hours, arrange for a trained specialist to relubricate or to replace the lubricating grease.	"G1" lubricating grease	139440
Fixed cutter blade	Turn over as needed	-	-
Fixed cutter blade	Replace as needed	-	-
Moving cutter blade	Turn over as needed	-	-
Moving cutter blade	Replace as needed	-	-
Ventilation slots	Clean as needed	-	-

Maintenance positions and maintenance intervals

Table 6

5.1 Changing the blade

Turning the moving cutter blade over or replacing it



Danger

Lethal danger possible due to electric shock!

- Pull the plug out of the socket when carrying out tool changes and before all maintenance work on the machine.

-
1. Position turning handle (27) to Stage "o" (ram in lower position).
 2. Loosen fixing screw (1s).
 3. Rotate moving cutter blade (5s) by 180° and remount it (or mount a new blade).
 4. Screw in fixing screw (1s) and tighten it. (see Fig. 14844, Pg. 13)

Turning the fixed cutter blade over or replacing it

1. Loosen fixing screw (1t).
2. Rotate fixed cutter blade (5t) by 180° and retighten the fixing screw (1t).

Note

Observe cutting clearance.

5.2 Replacing carbon brushes

The motor comes to a standstill when the carbon brushes are worn out.

- Have the carbon brushes checked and replaced as needed by a trained technician.

Note

Only use original replacement parts and observe the information on the type plate.

6. Wearing parts

Designation	Material number
2 Standard blade for the machining of mild steel	140451
2 Chromium steel blades for the machining of high-tensile sheets	140452

Wearing parts

Table 7

Note

Moving cutter blade (upper blade) and fixed cutter blade (lower blade) are identical in shape and can be used interchangeably (above or below).

All blades have two cutting edges. They are non-regrindable "2-way multi-edge or throw-away cutters".

Ordering wearing parts To ensure fast delivery of the correct original and wearing parts:

1. Give the order number.
2. Enter further ordering information:
 - Voltage information
 - Number of pieces
 - Machine type
3. Specify complete shipping information:
 - Correct address.
 - Preferred delivery type (e.g. air mail, courier, express mail, ordinary freight, parcel post).
4. Send the order to the TRUMPF representative office. For TRUMPF service addresses, see the address list at the end of the document.

7. Original accessories

Designation	Material No.
2 Standard blades (moving cutter blade and fixed cutter blade, mounted)	140451
Allen key DIN 911-2	002946
Allen key DIN 911-5	067857
Feeler gauge	056856
Lubricating grease "G1" (Tube)	344969
Grease gun	068624
Case	982541
Operator's manual	976147
Safety information (red document), other countries	125699
Safety information (red document), USA	1239438

Original accessories

Table 8

8. Options

Designation	Material No.
Traction eyelet	107668
Workstation	979371
Pedestal for workstation	003677
Workstation and pedestal	918382

Options

Table 9

